

**ARCON 2024 -  
KPCL welcomes to All Delegates**

# MISSION, VISION & OUR VALUES

**kirloskar**  
Pneumatic

## VISION

Sustainable  
Global Growth

We build on  
Speed | Quality

**K** | **P** | **C** | **L**  
Knowledge Management | People resources | Customer are | Leading Partnership

Mark "Kirloskar" used in any form as prefix or suffix is owned by Kirloskar Proprietary Limited and Kirloskar Pneumatic Company Limited in the Permitted Area.

**kirloskar**  
Pneumatic

## MISSION

We will demonstrate an edge to all our stakeholders in our offerings for converting/transmitting energy.

We will strive to make our company an employer of choice.

Mark "Kirloskar" used in any form as prefix or suffix is owned by Kirloskar Proprietary Limited and Kirloskar Pneumatic Company Limited in the Permitted Area.

**kirloskar**  
Pneumatic

## OUR VALUES

- EXCELLENCE**  
In everything we do, Quality without compromise
- INTEGRITY**  
Say what we do, and do what we say
- COLLABORATION**  
We grow with People and Partners
- EMPATHY** | Towards all Stakeholders  
We always Listen and Learn
- VALUE CREATION** | Towards all Stakeholders  
We're building for a shared prosperous future
- INNOVATIVE THINKING**  
Be Bold & Brave and stay Relevant

Mark "Kirloskar" used in any form as prefix or suffix is owned by Kirloskar Proprietary Limited and Kirloskar Pneumatic Company Limited in the Permitted Area.



# OVERVIEW - KPCL



Founded in 1958 by Mr. Shantanurao Kirloskar, Kirloskar Pneumatic Company Limited (KPCL) is one of the core Kirloskar group companies.



Headquarter In Pune, Maharashtra, India, 3 Manufacturing Facilities, 16 Branch offices.



**International Subsidiaries**  
KSEACL – South East Asia Co. Ltd.  
JITSPC – Kirloskar Trading SA Pty. Ltd.  
KDMCC – Kirloskar Direct Multi Commodities

## Products & Offerings



Air Conditioning  
And Refrigeration



Air Compressors



Process Gas  
Systems



Transmission



**Innovation in the present creates  
Limitless opportunities in the future.**



# ACR – AIR CONDITIONING & REFRIGERATION

ACR started with manufacturing of Air Conditioning & Refrigeration compressors (equipment group) and expanded into refrigeration projects and subsequently expanded into manufacturing Vapour Absorption Chiller



Refrigeration Equipment &  
Refrigeration Systems

Refrigeration Projects & Marine  
HVACR

Vapour Absorption  
Chillers

Spares & Service

## ACR - CAPABILITIES

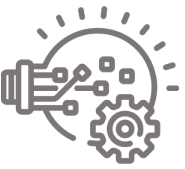

Innovation through  
Design & Development

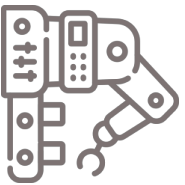

Manufacturing  
IoT Enabled



Largest Sales  
& Service Network



Supporting Large  
Installation Base



Training &  
Development

# MANUFACTURING

## MANUFACTURING FACILITIES AND CAPACITIES

<b>3</b>	<b>325 TR</b>	<b>800+</b>	<b>16+</b>
State Of Art Manufacturing Facilities	PERFORMANCE TEST FACILITY	Employee Strength	After Sales Support Locations



KPCL Hadapsar Plant, Total Area – 27 Acres & Build-up 30625 Sqm.



KPCL Saswad Plant, Total Area – 65 Acres & Build-up 15250 Sqm.

## KEY HIGHLIGHTS

<b>Leaders</b>	<b>1<sup>st</sup></b>	<b>1<sup>st</sup></b>
In INDIAN MARKET FOR AMMONIA REFRIGERATION Reciprocating Compressors	To Indigenously DESIGN & MANUFACTURE Screw Compressor	INDIAN COMPANY APPROVED FOR HYDROCARBON REFRIGERATION SYSTEMS



# MANUFACTURING BACKED BY IMS INTEGRATED MANAGEMENT SYSTEM



**IMS - Integrated Management System**



**ISO 9001 : 2015**



**ISO 14001 : 2015**



**ISO 45001 : 2018**



# COMPRESSORS AT THE HEART OF INDUSTRIAL REFRIGERATION

## RECIPROCATING REFRIGERATION COMPRESSORS & PACKAGES



**KCX - SINGLE STAGE & DOUBLE STAGE  
RECIPROCATING COMPRESSORS**

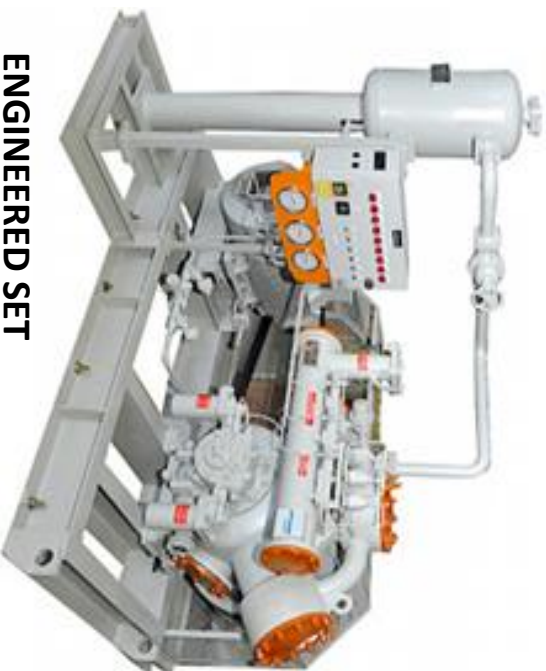

**ENGINEERED SET**



**PCX 1 & PCX 2 – SMALL YET  
POWERFUL REFRIGERATION  
COMPRESSORS**

**Kirloskar's reciprocating range of refrigeration compressors heralds the start of a completely new era for the industrial refrigeration market. From the inception of concept to the final delivery of this series, we continually put ourselves in the position of our Customers. Every component was assessed for the most important elements that contribute to a low Total Cost of Ownership like energy, maintenance and reliability with minimum downtime.**



# REFRIGERATION EQUIPMENT & REFRIGERATION SYSTEMS

## PRODUCT OFFERING - RECIPROCATING REFRIGERATION COMPRESSORS

### ENGINEERED SET – DELIVERING RELIABLE REFRIGERATION



#### Scope of Supply

- Compressor with Drive Set
- Suction and Discharge Stop Valves
- Oil Separator
- Common base frame for Compressor & Motor
- Belt Guard/Coupling Guard
- Gauges and Cutouts Board
- A Set of Special Tools, Gaskets and Oil Filter Kit
- Tubing and Ferrule
- 2 Nos. Stop Valves for oil return line
- 1 No. Y type Strainer for oil return line
- Refrigerant Piping from Compressor to Oil Separator
- Oil Piping from Oil Separator to Compressor
- Piping for Capacity Control & Gauge Tubing
- Swing Check Valve with Flanges & Bolts
- Motor

#### EFFICIENT AND ROBUST REFRIGERATION SET Offering

Temperature Range	Capacity
5°C to -45°C	10 to 500 TR



## SCREW REFRIGERATION COMPRESSORS & PACKAGES



**KRS – KHIONE SCREW  
COMPRESSOR**

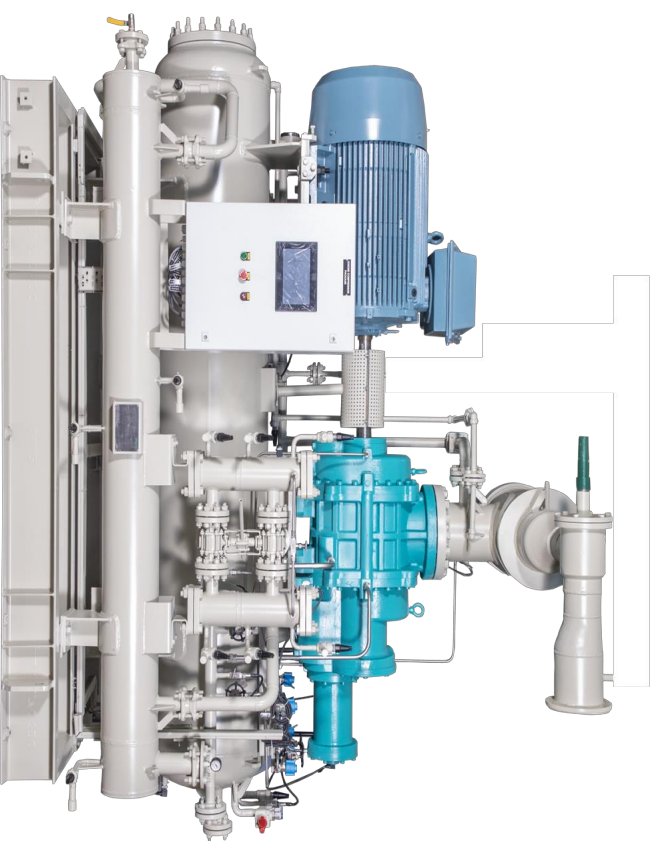

**KRS - SCREW PACKAGE**

**Kirloskar Pneumatic Company is India's first and only commercial developer and manufacturer of rotary twin screw refrigeration compressors, and remains at the forefront of the technology. We can provide oil injected units as stand-alone ('bare shaft') compressors or as packaged systems. Superior COP (Coefficient of Performance) values at full and part-load operation, modest capital investment, and low maintenance costs are some of the key benefits of KPCL's refrigeration packages.**

## KRS - REFRIGERATION SCREW COMPRESSOR RANGE:



**khione**

Sr. No.	Model	Swept Volume (m <sup>3</sup> /hr) At 3000 rpm
1	KRS-3145	1070
2	KRS-3165	1219
3	KRS-3193	1376
4	KRS-4133	1844
5	KRS-4150	2237
6	KRS-4115	1670
7	KRS-4170	2490
8	KRS-4195	2749
9	KRS-4225	3274

- **KHIONE** is primarily a name of Greek origin that means **Snow**
- **1<sup>st</sup> Indigenously Designed & Manufactured** Screw Compressor for Industrial Refrigeration.
- Screw Compressor package Conducive to all refrigerants (**NH<sub>3</sub>, R-22, R-134a, R-404A, R 407C, R507 etc.**

# Khione - compressors product details

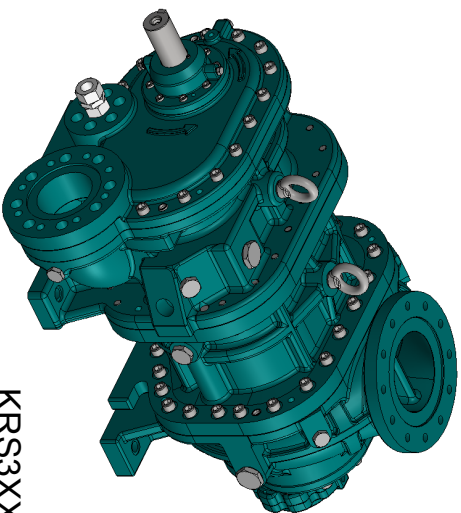

KRS3XXX

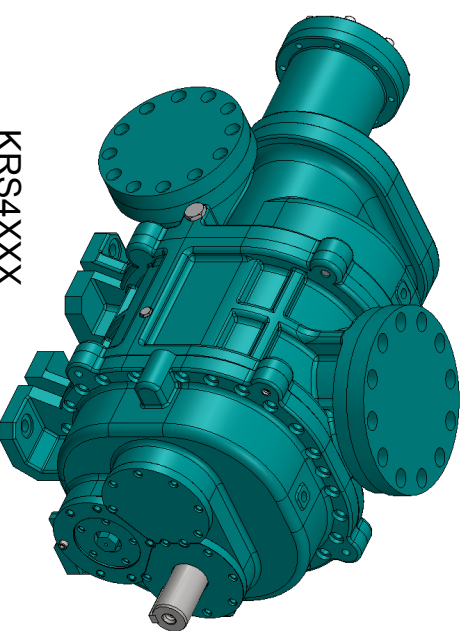

KRS4XXX

Sr No	Product model	Rotor detail		Flow rate (m <sup>3</sup> /hr)		Connection size NB		Dimensions 'mm'			Weight 'kg'
		Dia. (mm)	L/D	at 3000 rpm	at 3600 rpm	Suction	Discharge	L	W	H	
1	KRS3145	204	1.45	1101	1321	150	100	1293	676	560	855
2	KRS3165	204	1.65	1227	1473	150	100	1332	670	560	889
3	KRS3193	204	1.93	1376	1651	-	-	-	-	-	-
4	KRS4115	252	1.15	1670	2004	200	150	1503	655	760	1404
5	KRS4133	252	1.33	1844	2213	200	150	1548	637	760	1459
6	KRS4150	252	1.50	2237	2684	250	200	1660	724	783	1497
7	KRS4170	252	1.70	2490	2989	250	200	1710	724	783	1547
8	KRS4195	252	1.95	2749	3299	250	200	1960	724	783	1620
9	KRS4225	252	2.25	3274	3928	-	-	-	-	-	-

# KHIONE – REFRIGERATION SCREW CAPACITY RANGE



**Robust & Reliable  
Refrigeration Compressors**

## **Offering**

Temperature Range	Capacity
<b>-45°C to +5°C</b>	<b>50 to 900 TR</b>

- Variable Volume Ratio “V<sub>i</sub>”
- Economizer Port for Higher COP
- Optimum Lubrication
- Suction Temperature Range: (-) 45 to (+) 5°C
- Stepless Capacity Control Using Slide Valve
- Anti-friction Bearings

**khione**

**Reliable Compressors for Low Temperature Applications with High - Stage Booster combination  
delivering efficient refrigeration**

# SALIENT FEATURE – KHIONE REFRIGERATION COMPRESSOR



Anti-friction Bearings  
For Maximum Life



Low Cost of  
Ownership



Economizer Port  
For Higher COP

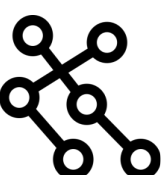

Vi - Variable Volume  
Ratio



Optimized Oil  
Injection



**khione**



Min/Max Operating  
Speed  
1450/3600 rpm

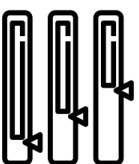

Step Less Capacity  
Control Slide Valve :  
10 To 100%

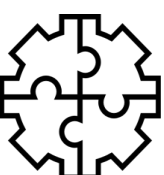

Discharge Port  
Convenient For  
Packaging



Robust & Reliable  
Design



+5 To (-) 45°C  
Evaporating  
Temperature Range

# SCREW COMPRESSOR PACKAGE:

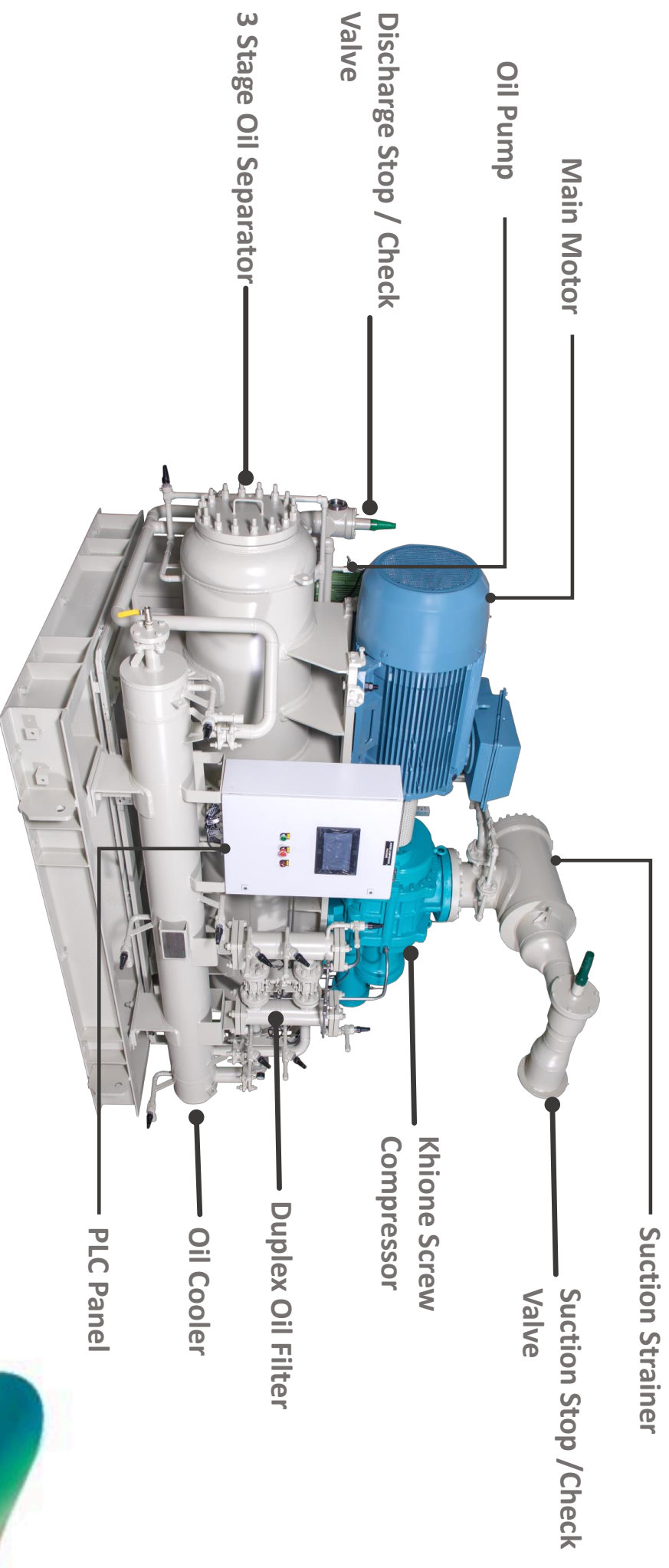

# KHIONE SCREW COMPRESSOR PACKAGE DETAILS

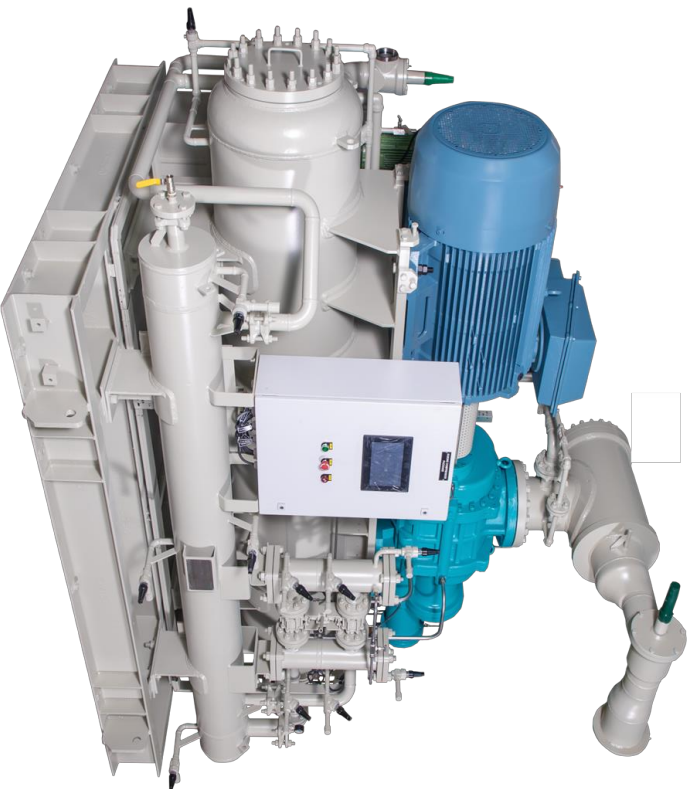

## **Oil Tank Separator (OTS)**

- Three-stage oil separation with gravity, Demister pad and Coalescer element
- Oil level switch
- Electrical heater with thermostat
- 3 bull's eye/sight glass
- Dual PSV with a two-position changeover valve is provided.

## **Oil cooler**

- Shell and tube type construction
- PHE-type oil cooler

## **Economizer**

- Open Flash, Shell and Tube Type Construction
- Improves the COP of the screw compressor package

# KHIONE SCREW COMPRESSOR PACKAGE DETAILS

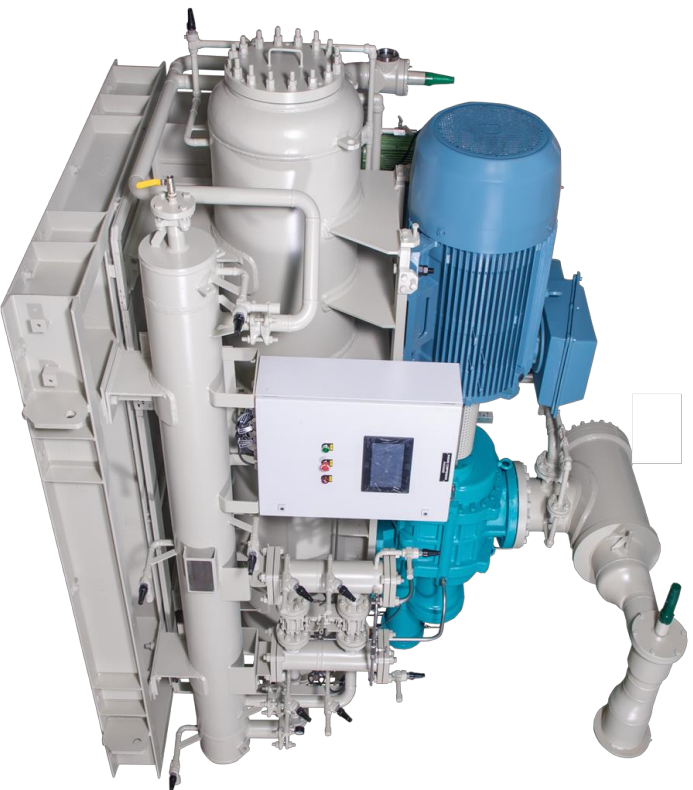

## Duplex oil filter

- It is provided with a changeover lever, which enables servicing of the filter element without interruption of compressor operation.
- Oil filter elements are replaceable.
- Nominal rating of 15 microns.

## PLC-Based Control Panel

- 10" touch-screen interactive HMI
- RMS Compatibility with MODBUS RTU RS 485 Compatible
- Parameters Settable at Site
- Password Protection Enabled
- Data Logging
- Features to Monitor, Regulate, and Protect Compressor Operation
- Safety Trips and Alarms on Display



## KHIONE SCREW COMPRESSOR PACKAGE DETAILS

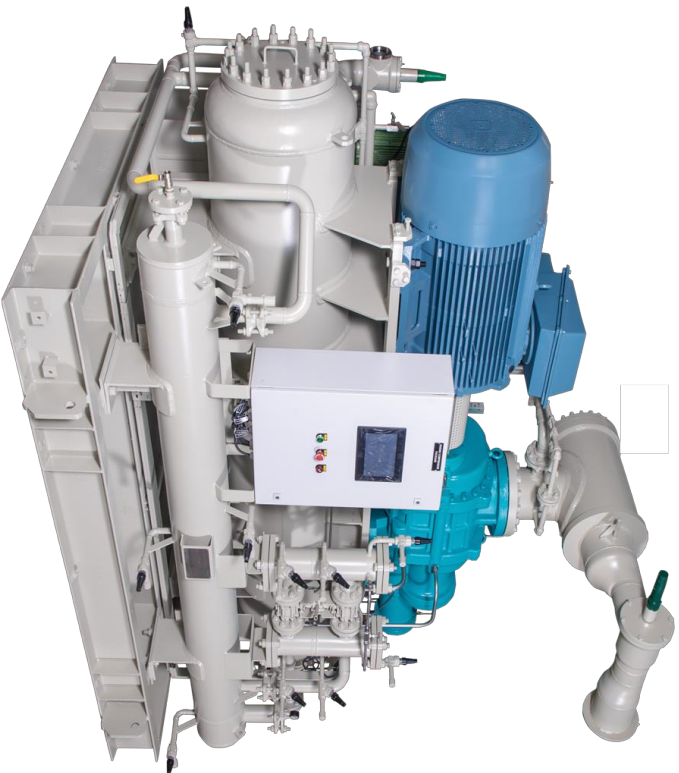

- Option available with electrical motor (IE2/IE3/IE4) as per requirement.

### **Interconnecting Valves and Controls**

- Valves and controls as per requirement.
- Valves and controls are of reputed makes

# TEST BED FACILITY WITH AMMONIA REFRIGERANT



# REFRIGERATION EQUIPMENT & REFRIGERATION SYSTEMS

## PRODUCT OFFERING

### KRMS – Kirloskar Remote Management System

#### Delivering Excellence Through Innovation

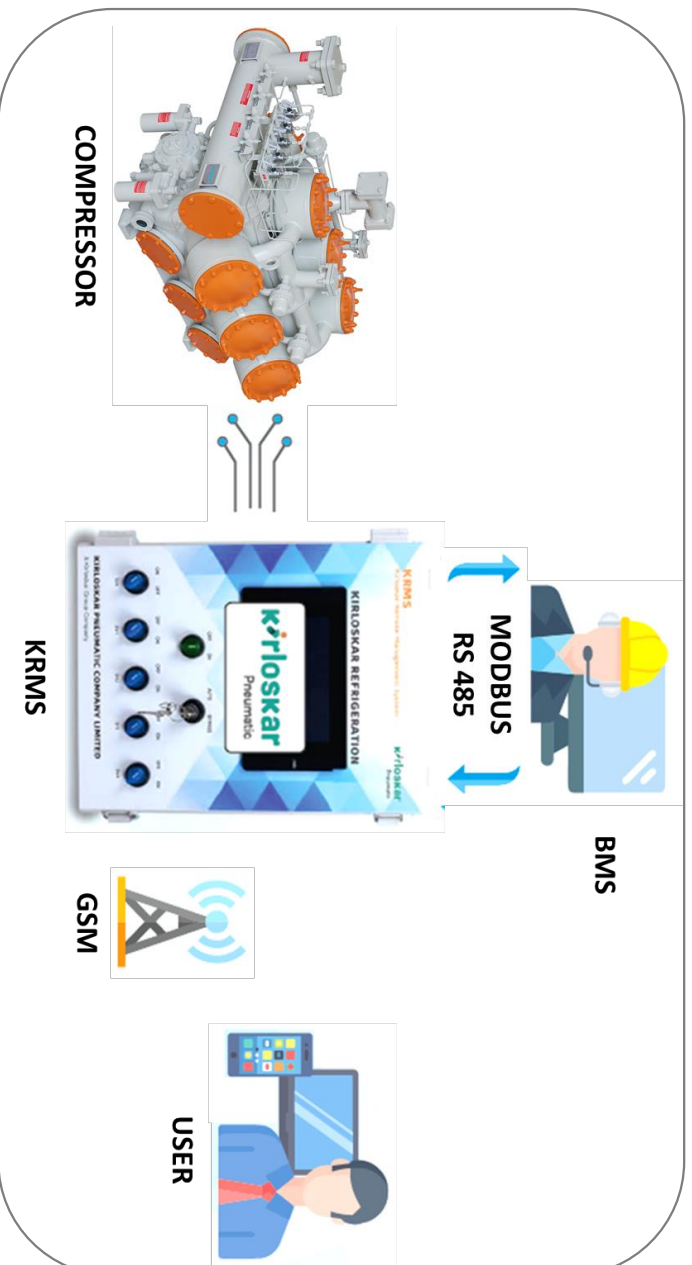

Enhanced Safety & Protection



Compressor Controller



Remote Monitoring of Compressor at Fingertips



Maintenance Monitor



Smart Diagnostics

# REFRIGERATION EQUIPMENT & REFRIGERATION SYSTEMS PRODUCT OFFERING GENUINE SPARES





- Kirloskar genuine spare parts are specifically designed and engineered to deliver performance and longevity to your compressors.
- All Kirloskar genuine parts are manufactured to the highest standards to match the individual compressor characteristics across the range and to fit exactly,
- Genuine spare parts reduces downtime and ensures reliability & consistency.

Kirloskar Genuine Spares Packaging Changes to **New Pre-printed Teal Green Packaging**  
(Pouch, Carton, and Skin Packing)

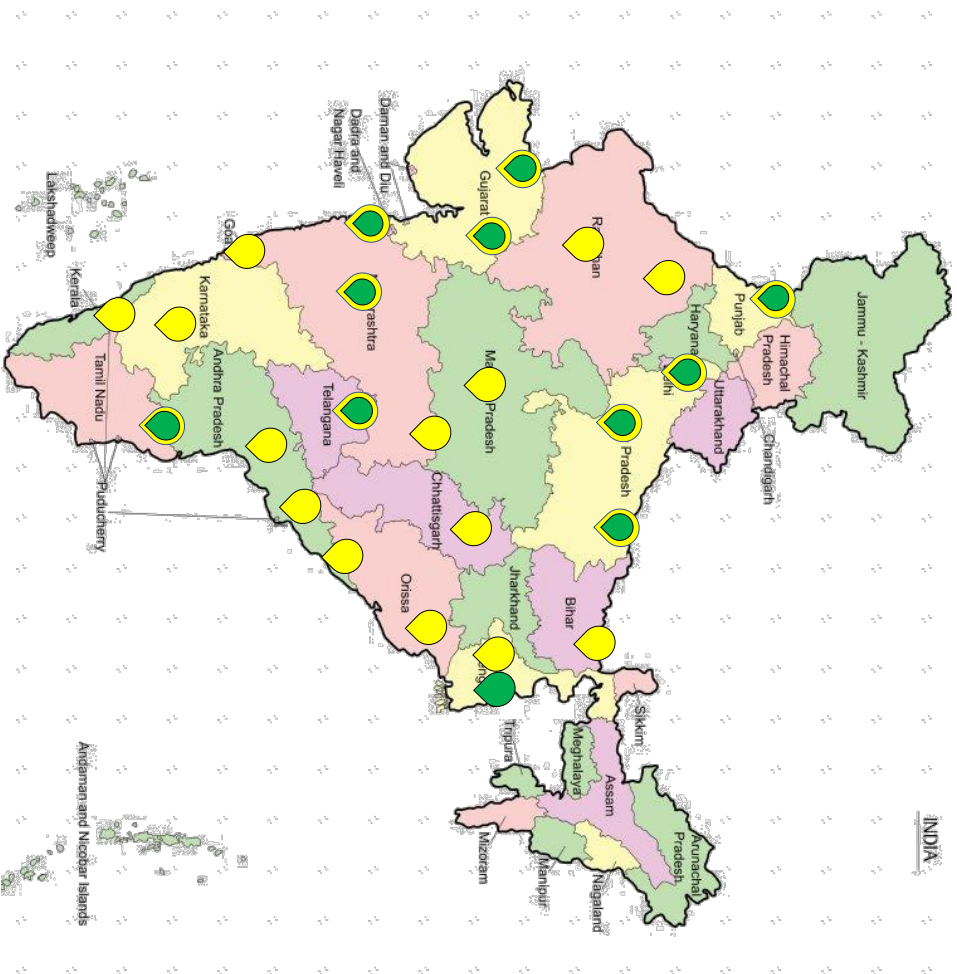
# LARGEST NETWORK IN THE INDUSTRY



-  Compressors, Spares and Services
-  Compressors
-  Spares and Services





---

# CSR

Corporate  
Social  
Responsibility

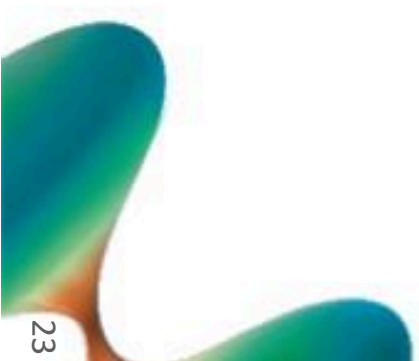



## KIRLOSKAR KASHI INITIATIVE

**kirloskar**  
Pneumatic

Kirloskar Pneumatic Company has raised this initiative to take a step towards girl education of Cold Storage Operators & Workers across India



**शिक्षा सहयोग किट  
वितरण**



# GLIMPSE - KASHI INITIATIVE

## बेटी बचाओ बेटी पढ़ाओ अभियान

राजधानी। डेढ़ी बरायों बेटी कोरड स्टडीज परसंस्परण के किलॉस्कर के मिस्टर कावजओ ने बरन पढाओ अभियान की कड़ी का जनरल सैक्रेटरी मिस्टर यश राजेश पाटिका व मिस्टर समीर सहयोग किरट पाके कजो बर्निस किलॉस्कर न्यूमैटिक कोरड स्टडीज परसंस्परण की बाबूश्री रूप से सम्मोहित व मिनिस्ट्र की ओर ने



आयोजित कार्यक्रम काशी के तबत 24 फरवरी 2023 का सञ्चालन के शेटल मरीयल सञ्चालन के का रड स्टडीज ऑपरटर्स की शेटिया की शिवा सहयोग किरट पाटी गड, किलॉस्कर न्यूमैटिक कम्पनी सञ्चालन के रड स्टडीज परसंस्परण ओर उतर प्रदेश के सहयोग से हर वर्ष किये जाने वाले इस कार्यक्रम में छात्राओं को किलॉस्कर के मॉडल प्रिजेंट (इंटरनेशनल मॉकेटिंग) मिस्टर किलॉस्कर किलॉस्कर के मॉडल प्रिजेंट (इंटरनेशनल मॉकेटिंग) मिस्टर किलॉस्कर के मॉडल प्रिजेंट (इंटरनेशनल मॉकेटिंग) मिस्टर



## बेटी बचाओ बेटी पढ़ाओ अभियान

देश को रोशनी, संवाददाता।

राजधानी। बेटी बचाओ बेटी पढ़ाओ अभियान की कड़ी को ओर बढ़ाते हुए मेसर्स किलॉस्कर -यू.पी.टि.क लिमिटेड को ओर से आयोजित काशी के तबत 24 फरवरी 2023 को लखनऊ में कोरड स्टडीज ऑपरटर्स की शेटिया सहयोग किरट पाटी गड, किलॉस्कर न्यूमैटिक कम्पनी सञ्चालन के सञ्चालन के शेटल मरीयल सञ्चालन के का रड स्टडीज ऑपरटर्स की शेटिया की शिवा सहयोग किरट पाटी गड, किलॉस्कर न्यूमैटिक कम्पनी सञ्चालन के रड स्टडीज परसंस्परण ओर उतर प्रदेश के सहयोग से हर वर्ष किये जाने वाले इस कार्यक्रम में छात्राओं को किलॉस्कर के मॉडल प्रिजेंट (इंटरनेशनल मॉकेटिंग) मिस्टर किलॉस्कर के मॉडल प्रिजेंट (इंटरनेशनल मॉकेटिंग) मिस्टर किलॉस्कर के मॉडल प्रिजेंट (इंटरनेशनल मॉकेटिंग) मिस्टर



राजधानी। बेटी बचाओ बेटी पढ़ाओ अभियान की कड़ी को ओर बढ़ाते हुए मेसर्स किलॉस्कर -यू.पी.टि.क लिमिटेड को ओर से आयोजित काशी के तबत 24 फरवरी 2023 को लखनऊ में कोरड स्टडीज ऑपरटर्स की शेटिया सहयोग किरट पाटी गड, किलॉस्कर न्यूमैटिक कम्पनी सञ्चालन के सञ्चालन के शेटल मरीयल सञ्चालन के का रड स्टडीज ऑपरटर्स की शेटिया की शिवा सहयोग किरट पाटी गड, किलॉस्कर न्यूमैटिक कम्पनी सञ्चालन के रड स्टडीज परसंस्परण ओर उतर प्रदेश के सहयोग से हर वर्ष किये जाने वाले इस कार्यक्रम में छात्राओं को किलॉस्कर के मॉडल प्रिजेंट (इंटरनेशनल मॉकेटिंग) मिस्टर किलॉस्कर के मॉडल प्रिजेंट (इंटरनेशनल मॉकेटिंग) मिस्टर किलॉस्कर के मॉडल प्रिजेंट (इंटरनेशनल मॉकेटिंग) मिस्टर





## **FOR MORE DETAILS PLS CONTACT :**

### **HO (PUNE):**

**Contact Person** – Mr. Harshad Vaidya

DGM – Sales Domestic

Email Id – [harshad.vaidya@kirloskar.com](mailto:harshad.vaidya@kirloskar.com)

Mob: +91 98509 69402

### **SOUTH REGION:**

**Contact Person 1** – Mr. Anjaiah

DGM – SOUTH REGION (ACR)

Email Id – [y.anjaiah@kirloskar.com](mailto:y.anjaiah@kirloskar.com)

Mob: +91 9440925509.

**Contact Person 2** – D. Trimala Patro

SR. MGR – SALES & SERVICE (ACR)

Email Id – [trimala.patro@kirloskar.com](mailto:trimala.patro@kirloskar.com)

Mob: +91 9790924180.